

INSTRUCTIONS:

J Series Track

Safety Instructions:

1. Read all instructions.
2. Turn off power at main switch before installing or modifying the system.
3. Do not install within six inches of any curtain or combustible materials.
4. Do not install less than 5 feet above a floor.
5. Do not install in damp or wet locations.
6. Do not install concealed, or extended through building walls.
7. Do not attempt to energize anything other than a track light fixture.
8. Do not connect a track to more than one branch circuit. Although track light systems may seem to operate acceptably, a dangerous overload of the neutral may occur and result in a risk of fire.
9. Check with a qualified electrician before wiring.
All installation shall be in accordance with NEC and all local codes.

Electrical Feed From A Junction Box with Floating Canopy

The floating canopy covers a junction box and brings power to the track anywhere along its length.

1. Make sure power is off.
2. Secure cross bar to the junction box.
3. Hold track to the ceiling and mark the position of mounting holes.
4. Secure track between the scratch brackets located on the cross bar.
5. Mount track to ceiling following track mounting instructions (see track mounting section).
6. Position electrical adapter into track, turn 90° to install. Route wires along the side of track into the junction box.
7. Connect neutral (white) and hot (black) wires from the ceiling with their respective wires from the track adapter, with wire nuts (supplied).
8. Connect ground wire from ceiling to green grounding wire from adapter, with a wire nut (supplied).
9. Tuck excess wire back into the junction box.
10. Replace canopy cover and secure with screw.

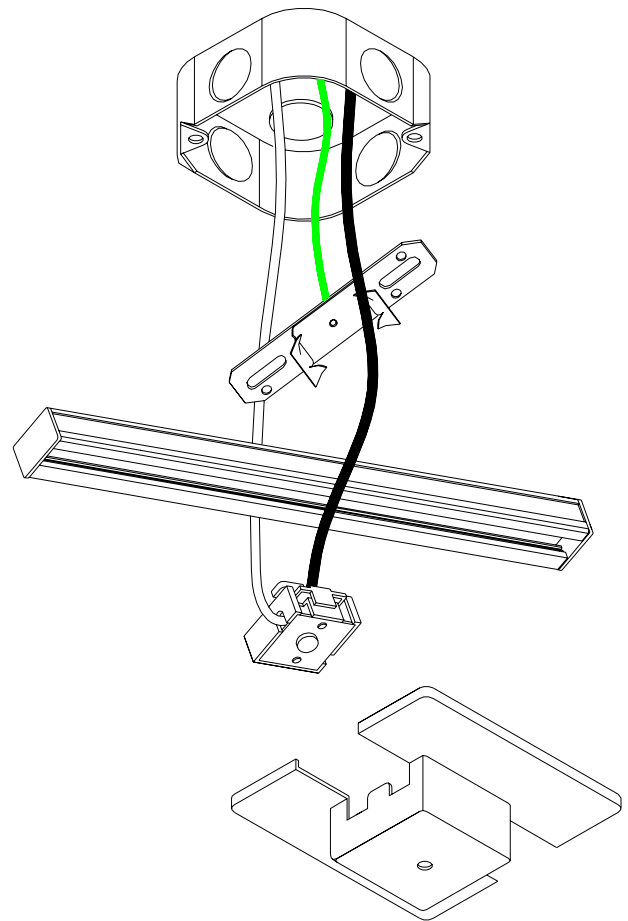

Live End Electrical Feed Over a Junction Box

1. Make sure power is off.
2. Note the polarity indicator of the track. The live end can only be installed on one end. Brace the track end cap (opposite the live end) against a solid surface, and insert live end. This is important to achieve good electrical contact.
3. Position live end over center of junction box. Mark track-mounting holes.
4. Remove live end cover and pry out the knock out hole.
5. Use a canopy plate "CP". Attach mounting plate to junction box. Note plate has threaded screw holes, the remaining screw will fit in a slotted hole to permit positioning. The plate will protrude slightly beyond the junction box, but will be covered when completed.
6. Connect neutral (white) wire to the silver screw terminal on the live end marked "N" and Hot (black) wires to the brass colored screw terminal marked "A" on the live end.
7. Connect Ground wire to green wire or screw terminal on the live end. Tuck any excess wire back into the junction box.
8. Replace live end cover and secure with screw.
9. Install the canopy cover to the canopy plate with one screw and the cut out facing the track length.
10. Mount track (see Track Mounting).

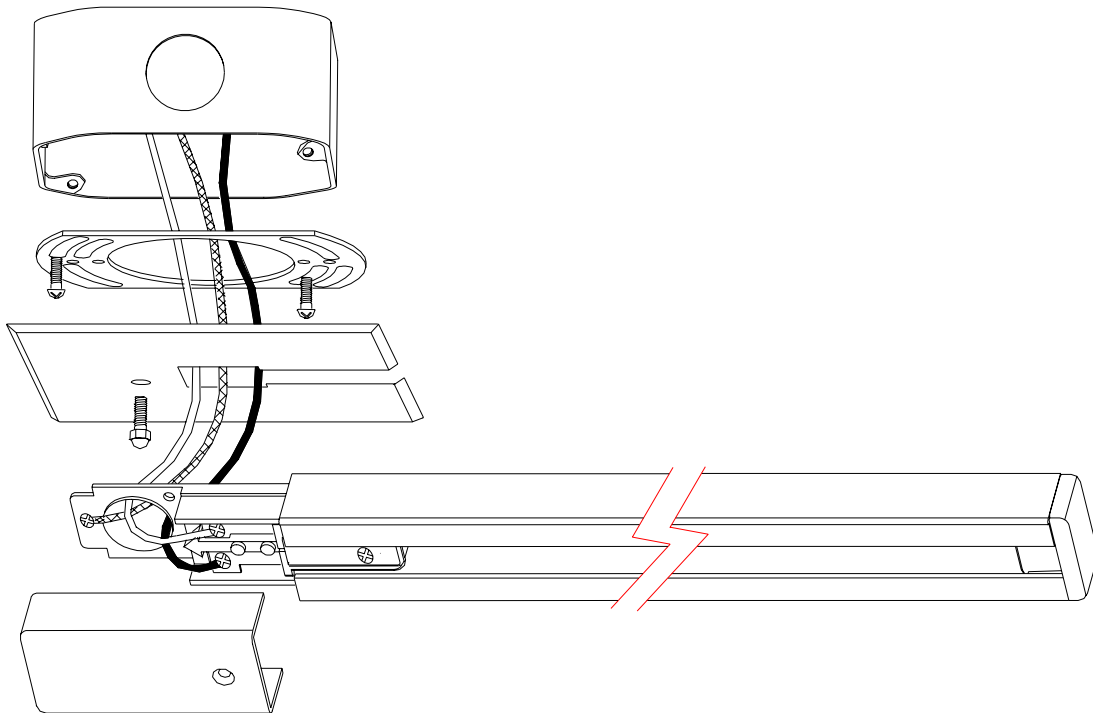

Use "T" bar clip for grid ceilings.

Mounting Track

1. Raise track assembly to ceiling. Mark mounting hole locations. Track support points should be not more than 4' apart. Use a minimum of two support points for 2' and 4' track and three for 6' and 8' track.
2. Drill ceiling holes suitable for the fasteners you intend to use. Toggle wings (supplied) require 1/2 inch holes.
3. If additional holes in track are needed, drill 5/32" holes through the centerline of track (locate holes at least 6" in from track ends).
4. Insert bolts through track, and into the toggle wings, tighten 2 or 3 turns.
5. Push toggle wings into ceiling holes. Do not fully tighten toggle bolts until all electrical connections are made.

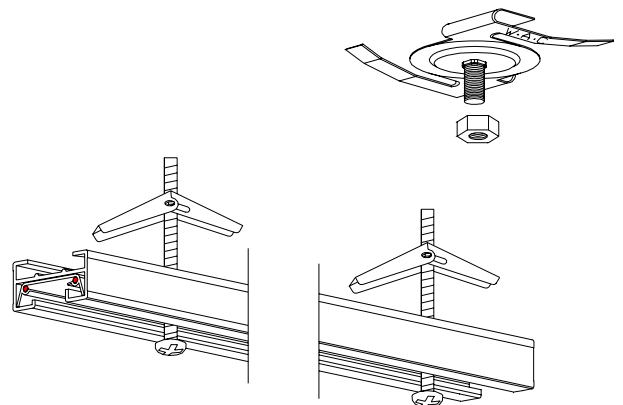

Field Cutting Continued

3. Make a flush cut through track with a fine-toothed hacksaw. File any rough edges or flash. Brush out any remaining filings.

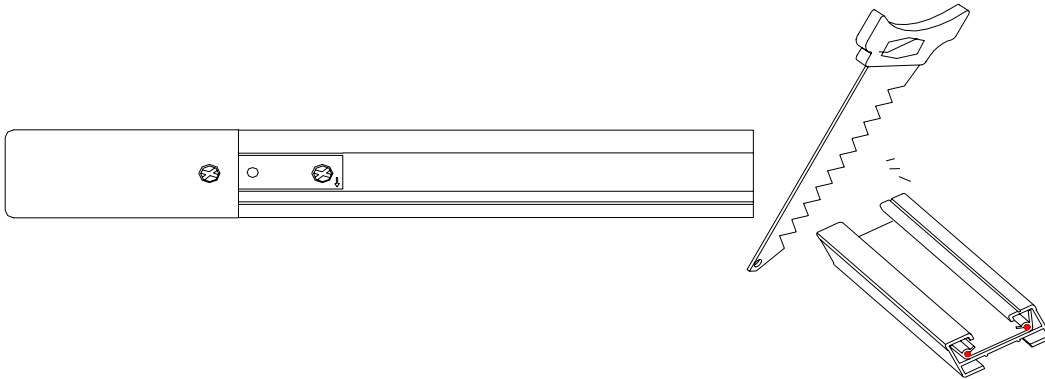

4. Once the flush cut is made trim 5/16" off the end of the copper bus wire. This will allow sufficient clearance for the end cap or a mating connector. If not performed in this sequence the bus wires will be short and cause faulty contact.

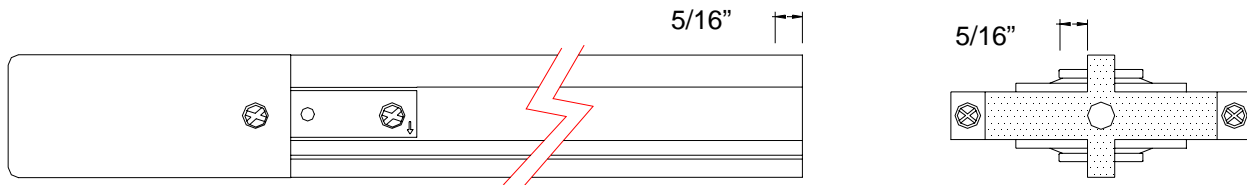

5. When mating to connector already at ceiling level make sure to support connectors at both ends.

Retain instructions for future reference.

